

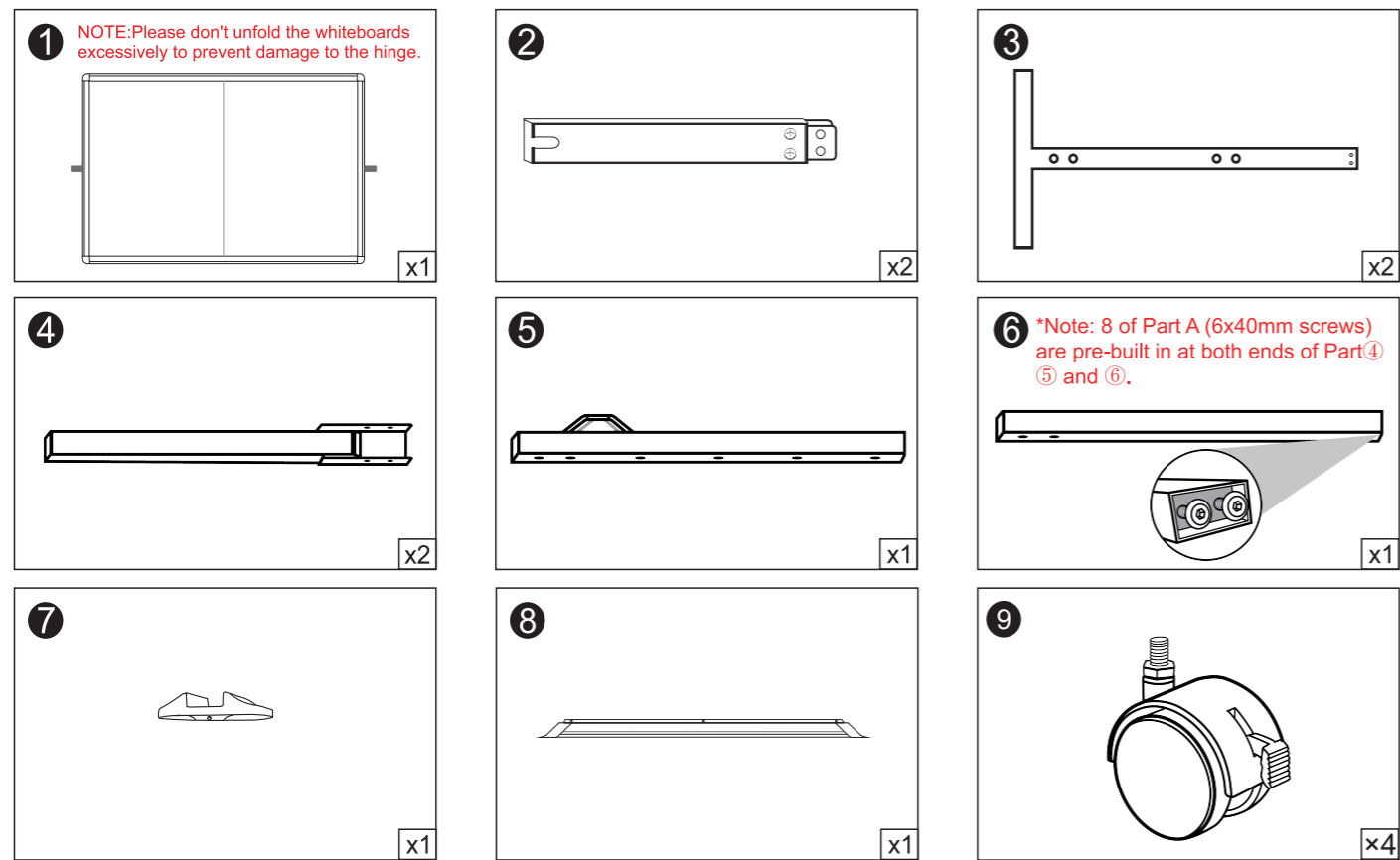











Before Assembly

When you unpack and prepare for assembly, please place the contents on a carpeted or padded area to protect them from damage.

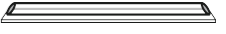

Part	Qty	Name	Refer Picture	Part	Qty	Name	Refer Picture
A	8	6*40mm Screw		G	2	4*10mm Screw (Gold)	
B	4	4*10mm Screw (Silver)		H	8	5*8mm screw	
C	1	Screwdriver		I	8	6*8mm screw	
D	1	Spanner		J	2	Connecting Bar	
E	1	Wrench		K	4	4.2*16mm screw	
F	2	Plastic Mat		L	Several	Spare Parts	

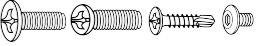
Tips for using the whiteboard

- Each whiteboard is covered with a plastic protective film that aims to protect the surface of the product. Please make sure that you have peeled it off before using.
- For the pens, it is recommended to use a water-based pen for all our whiteboards because of the special material of board (Please don't use oil-based pens).
- For the board surface, if the board looks dirty, please wipe it with a damp cloth or wet tissue, or you can use the whiteboard cleaner/lightly-dampened alcohol, so the board can be used just as new after drying.
- Before using, check the board surface if it's clean, no dirt, no water stains or no alcohol residue on it.

Step 1

Connect Part ② with ③ and tighten them with Part H. (Auxiliary Tool: Part C)

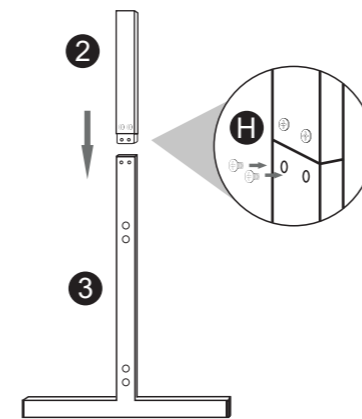

Step 2

Screw Part ⑨ into Part ③ (Auxiliary Tools: Part E)

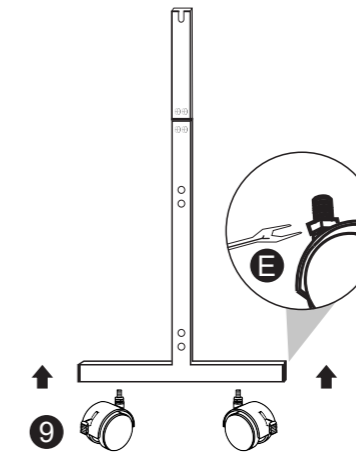

Step 3

Connect Part ④ with ⑤ and tighten them with Part I. Connect Part ④ with ⑥ with the same operation (Auxiliary Tool: Part D)

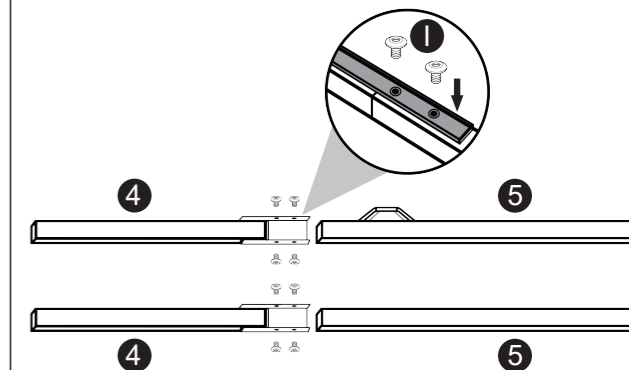

Step 4

Use Part B install Part ⑧ to Part ⑤ first and then use Part G install Part ⑦ to Part ⑤ (Auxiliary Tool: Part C).

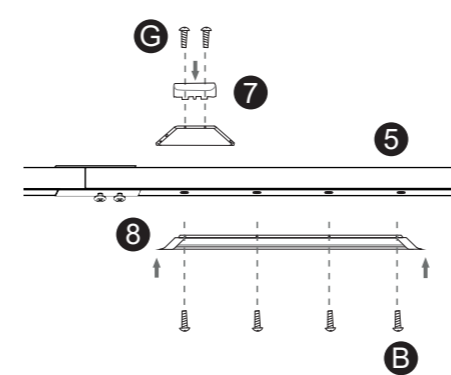

Step 5

Use Part A install the metal bar to Part ③ (Auxiliary Tools: Part D)

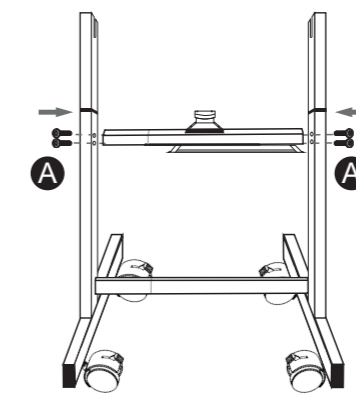

Step 6

Unfold whiteboard and fix the upper and lower frame with Part J and Part K. Then put the whiteboard on the shelf and insert Part F (Auxiliary Tools: Part C)

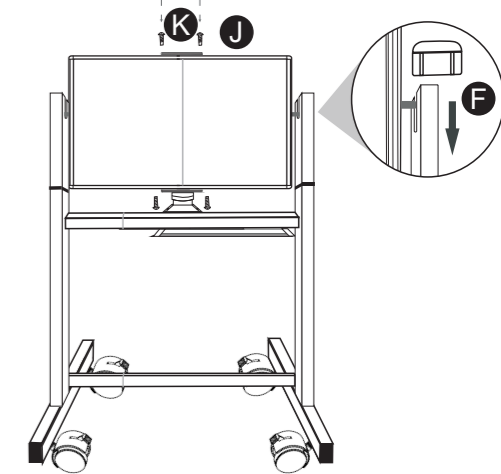

A blue oval graphic with a white border, containing the text 'Mobile Whiteboard User Manual'.

**Mobile Whiteboard
User Manual**